



Transforming the best of
two worlds into one solution.
Siemens **Transformers.**

Large Distribution Transformers.

Power Transmission and Distribution

SIEMENS

Knowledge and technology, swiftness and simplicity

Siemens, pioneer and leader in the electrotechnical industry, has more than 100 years experience designing and manufacturing power and distribution transformers. Currently it has 18 manufacturing locations worldwide, strategically located to attend global demand, fulfilling the strictest standards with the best quality indicators at global level.

Smaller dimensions, same performance

Developed in cooperation between the Siemens factories of Portugal, Colombia, Brazil and Pakistan, the Large Distribution Transformer (LDT) concept offers the best of two worlds: the performance of the power transformers, with the simplicity, standardization and rationalization of costs and dimensions of the distribution transformers. Concepts such as DFM (Design for Manufacturing), tridimensional CAD (Computer Aided Design) and FEA (Finite Elements Analysis) were used in conceptualization of this product.

Simplicity, flexibility and speed in design give our customers the possibility to obtain better prices and delivery times.

With costs compatible to their budgets, customers can now acquire a medium-sized power transformer, with the habitual Siemens quality guarantee, but more competitive in price and delivery time. Everything thanks to LDT technology.

Technical characteristic:

- From 5 to 30 MVA (ONAN/ONAF)
- Maximum service voltage 145 kV (AC/LI 275/650 kV)
- LV windings preferable foil or layer execution
- HV windings preferable layer or discs execution (including transposed conductors)
- Noload or onload tapping (NLTC or OLTC)

Productivity improvement:

- High rationalization of engineering costs (electrical and mechanical design hours)
- High rationalization of production costs (process hours, material and pieces quantity)



Oil thermometer



Drain valve



Oil sampling valve



Dehydrating breather

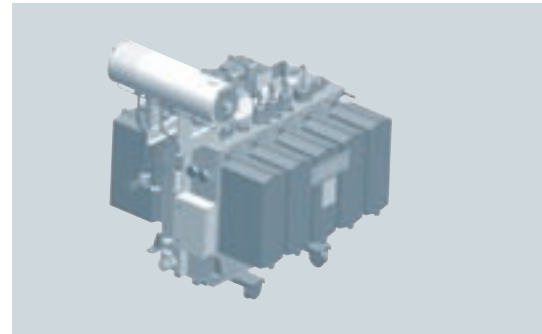

LDT designed in Pro/ENGINEER®

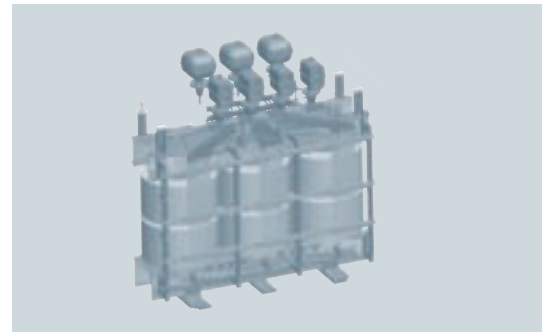

Active part designed in Pro/ENGINEER®

Siemens technician checks the control cabinet

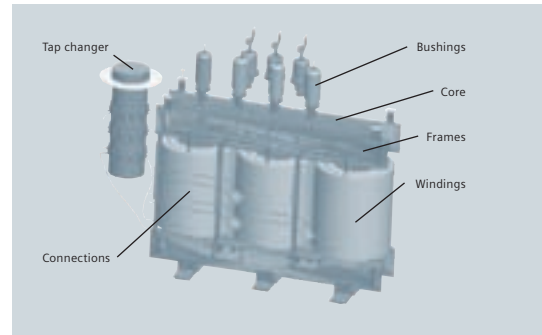

Main components of the active part

15/20 MVA LDT,
46 +/- 8 x 1.875 % / 6.3 kV,
OLTC, for Ecuador

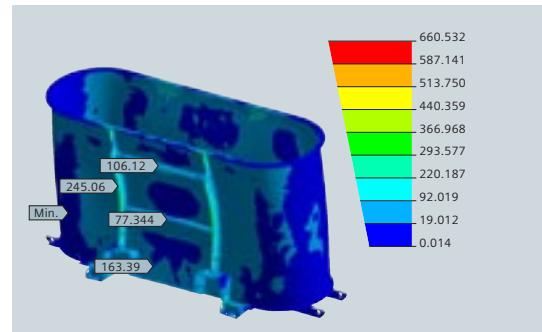

Stress calculation of the tank

Double-tier transformer, with
forced-air ventilation, 9/12 MVA,
for Costa Rica



Siemens, Ltda
Power Transmission and Distribution
Transformers Division
Av. João F. G Molina, 1745
13213-080, Jundiaí
Brazil
Tel.: +55 1145852000
Fax: +55 1145852020
E-mail: evtvendas@siemens.com.br

Siemens, SA
Power Transmission and Distribution
Transformers Division
Carrera 65 No. 11-83
Bogotá
Colombia
Tel.: +57 (1) 2942568
Fax: +57 (1) 2942694
E-mail: trafosdistribucion@siemens.com

Siemens, Ltd
Power Transmission and Distribution
Transformers Division
B-72, Estate Avenue, S.I.T.E.
Karachi-75700
Pakistan
Tel.: +92 21574910
Fax: +92 212577791
E-mail: ishtiaq.haq@siemens.com

Siemens, SA
Power Transmission and Distribution
Transformers Division
Apartado 501
Sabugo 2715 981
Portugal
Tel.: +351 21 9627309
Fax: +351 21 9627293
E-mail: factorysabugo@siemens.com

Siemens AG
Power Transmission and Distribution
Transformers Division
Katzwanger Str. 150
90461 Nuremberg
Germany

t-sales.ptd@siemens.com
www.siemens.com/energy

If you have any question about
Power Transmission and Distribution,
our Customer Support Center is
available around the clock.

Tel.: +49 180 / 524 70 00
Fax: +49 180 / 524 24 71
(Subject to charge: e.g. 12 ct/min)

E-mail: support.energy@siemens.com
www.siemens.com/energy-support

Order No. E50001-U410-A113-X-7600
Printed in Germany
Dispo 19200
GB 06702 102078 WS 10062.